

OLA ELECTRIC

SHAREHOLDERS' LETTER

Q4 FY26 | MAY 20, 2026

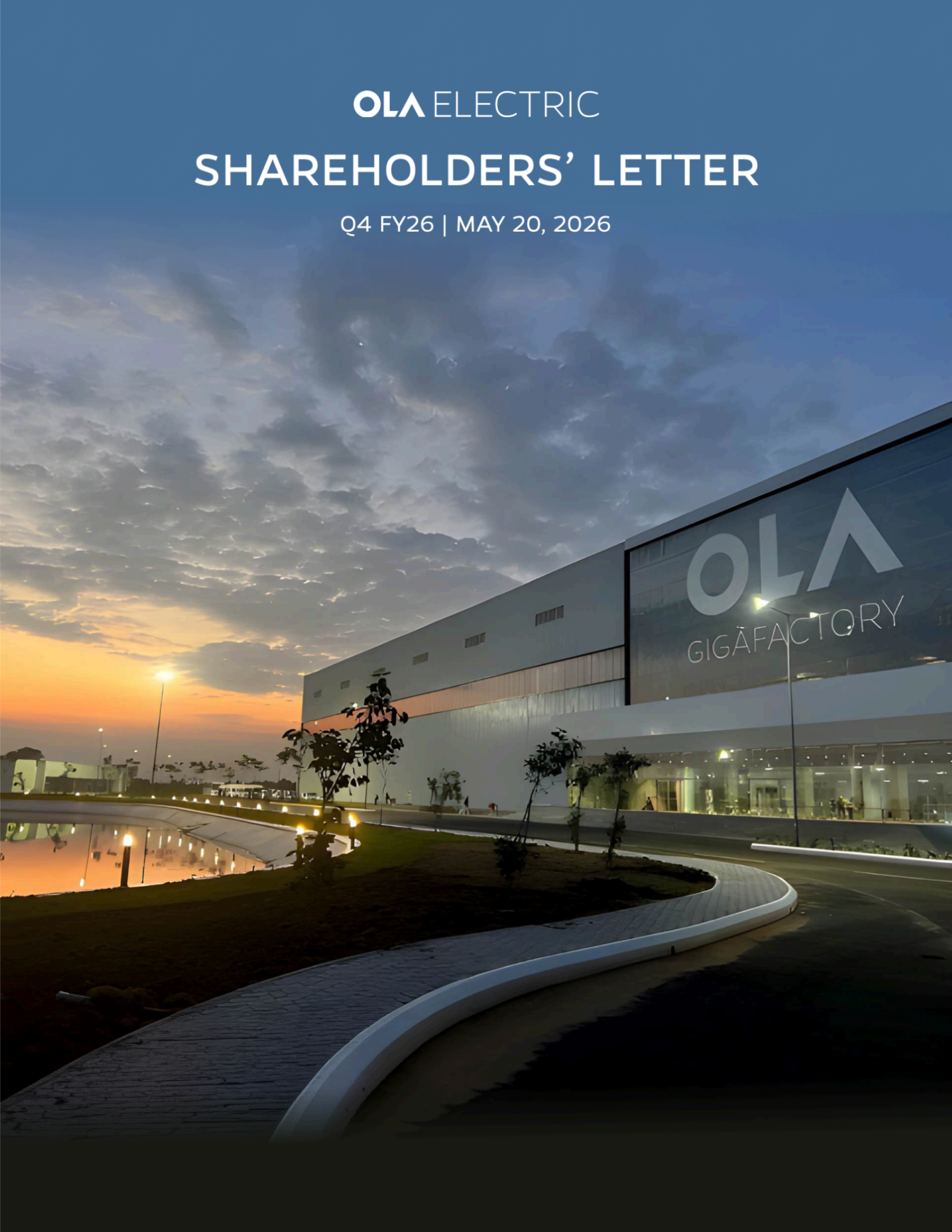

उद्धरेदात्मनात्मानं नात्मानमवसादयेत् । आत्मैव ह्यात्मनो बन्धुरात्मैव रिपुरात्मनः ॥

Bhagavad Gita 6.5

FY26 Key Highlights

₹2,253 Cr
Consolidated
Revenue

173,794
Deliveries

30.6 %
Consol
Gross Margin

-53.4 %*
Consol Adj. EBITDA
Margin

Q4 FY26 Key Highlights

₹265 Cr
Consolidated
Revenue

20,256
Deliveries

38.5 %
Consol
Gross Margin

-123.0 %*
Consol Adj. EBITDA
Margin

**Adj. Operating EBITDA Margin refers to Operating EBITDA (excluding other income) including the lease expenses*

Q1 FY27 Expectation:

₹500-₹550 Cr
Consolidated Revenue

40K-45K
Orders

Dear Shareholders,

FY26 was a year of reset for Ola Electric.

We used the year to strengthen the fundamentals of the business - service, product quality, gross margins, operating costs, cash discipline, sales productivity and cell manufacturing. Q4 was a low volume quarter, but it also showed the reset working: **gross margin reached 38.5%**, **opex reduced materially through the year**, **cash burn reduced significantly**, **service stabilised**, and **sales recovery began**, while cell moved from the validation phase to scale. This is the milestone we had set for ourselves in the current quarter and we have delivered the promise.

India is entering a defining energy-security moment. Global energy volatility and oil-market disruptions have made dependence on imported fossil fuels a critical consumer, economic and policy issue. For consumers, **higher petrol and diesel prices sharpen the cost-of-ownership advantage of EVs**. For the government, **EVs, local cell manufacturing and battery storage are converging into one national energy-security stack**.

Ola was built for this moment. We are the only company positioned across the two most important pillars of India's energy future - **electric mobility and batteries**. Our vehicles create captive demand for the Gigafactory, allowing us to ramp cell manufacturing at meaningful commercial volumes from the start. Our cells further benefit our EVs through range, cost and supply-chain control and creates a base for Ola to enter energy storage through **Shakti and Mahashakti**.

In auto, service was the most important operating focus. **Service has now materially stabilised.** Average TAT reduced, parts availability improved, technician productivity increased and repair capability strengthened. Gen 3 is also reducing service demand at the product level. As service improved, we have experienced a **V-shaped sales recovery** from Q4, with April registrations up **20% month-on-month** even as the broader E2W industry declined by more than **22%**. **This improvement is also visible in our P&L: warranty cost in the current year stands at ₹59 crore, compared with ₹555 crore in FY25.**

The brand remains strong. Ola continues to **lead the EV category** in salience and cumulative installed base, and customer feedback reinforces that the core product-market fit remains intact.

FY26 also expanded Ola beyond a scooter-led business. **Roadster** gives us access to India's largest two-wheeler category - motorcycles - where electric penetration is still very low. Gen 3 gives us a stronger quality and cost platform. AI is now embedded across sales, service and operations, helping us sell better, service faster and scale leaner.

The Gigafactory is entering its next phase. FY27 is about ramping commercial manufacturing towards **6 GWh**, integrating our cells deeper into the auto portfolio, and building Shakti and Mahashakti as external demand engines. **LFP is an important part of this roadmap**, and the overall objective is to scale the Gigafactory into a platform serving both mobility and energy storage.

Our FY27 priorities are clear: sustain service consistency, scale volumes with discipline, improve auto cash generation, ramp the Gigafactory, and build the storage business.

Financial commentary

Q4 is the first operating cash-flow positive quarter

Q4 was a low volume quarter, but also the first **operating cash-flow positive quarter**.

Consolidated CFO was **₹91 crore**, supported by PLI inflows, stronger gross margins, lower opex and tighter working-capital discipline. Consolidated FCF improved to **-₹131 crore**.

Auto delivered **₹213 crore CFO** and **₹173 crore FCF** in Q4. Cell remained in planned investment mode as we ramp the Gigafactory and prepare the next phase of cell and storage products. Since auto and cell are at different stages, we have provided a management view of segment cash flow in the financials section, including the Corporate / Unallocated bridge in the appendix.

Industry-leading gross margins

Our product economics continued to strengthen. **Consolidated gross margin reached 38.5% (33.5% excl. PLI) in Q4 FY26**, up from 34.3% in Q3 and 13.7% in Q4 FY25.

This is now an industry-leading gross margin profile, meaningfully ahead of most two-wheeler OEMs, including ICE incumbents. It reflects **vertical integration, Gen 3 maturity, pricing architecture and downstream control**.

Owing to the current geopolitical uncertainties, Gross margins may moderate in Q1 and Q2 FY27 due to commodity inflation and pricing actions to accelerate growth. But we have the margin buffer to stay aggressive on price and customer value while maintaining strong unit economics.

Strong Gross margin expansion:

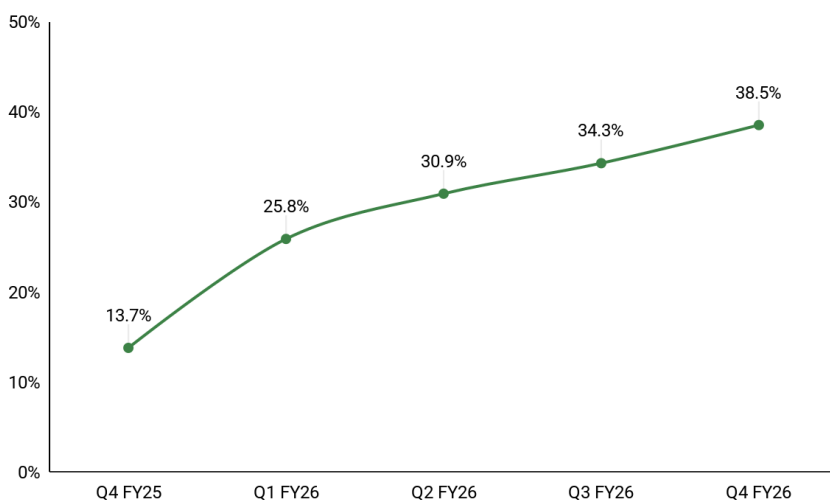

Opex reset and operating discipline

FY26 was also a year of cost reset. **Consolidated operating expenses, including lease rentals, reduced from ₹844 crore in Q4 FY25 to ₹428 crore in Q4 FY26**. This came from network rationalisation, tighter sales and service costs, lower fixed overheads and stronger operating governance.

We expect opex to reduce further towards **₹350 crore per quarter** over the next couple of quarters as the full benefit of FY26 actions flows through. This gives us a much better cost structure as volumes recover.

Cash flow improved materially through the year. Consolidated CFO improved from **-₹2,391 crore in FY25 to -₹775 crore in FY26**, while consolidated FCF improved from **-₹3,367 crore to -₹1,492 crore**. **Auto was the largest contributor** to this improvement, with FCF improving from **-₹2,597 crore to -₹661 crore**.

Consolidated Operating expenses (₹ crore)*:

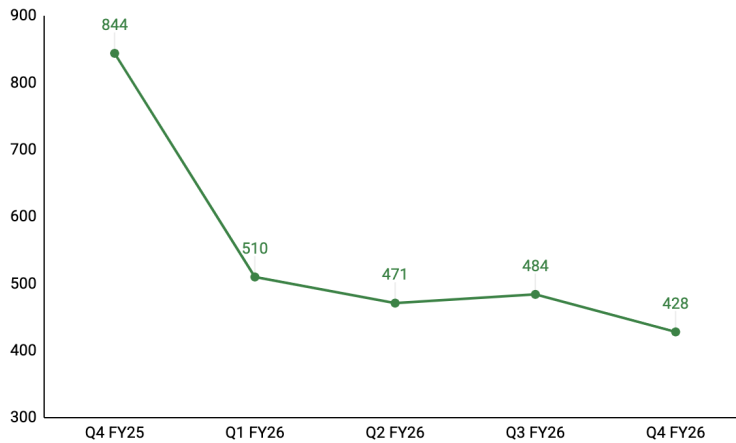

*Consolidated Operating expenses including lease expenses

Gross block and operating leverage

Over the last few years, we have built a large gross block across the Ola Futurefactory, the Gigafactory, product platforms, service infrastructure and cell technology. **This gross block is our competitive advantage.** It gives us capacity, vertical integration, technology depth and speed to market that are difficult to replicate.

Our gross block is **5x EV pure-play peers**, reflecting the depth of our investment in manufacturing, vertical integration and cell technology. The value of this asset base will become more visible as volumes scale.

The core auto capex is already in place for up to **1 million vehicles of annual capacity**. The Gigafactory Phase 1 infrastructure is in place for the **6 GWh scale-up**. Together, this gross block can support about **₹15,000–20,000 crore** of revenue scale across auto and cell without a need in incremental capex.

The next phase is about utilisation. With the reset opex base and current gross margin structure, the business has a much lower breakeven volume. At around **₹300 - 350 crore of quarterly opex**, adjusted operating EBITDA breakeven is achievable at **20,000 - 25,000 units per month**, subject to pricing, mix and commodity conditions.

Our financial priorities are clear: **recover volumes, hold strong gross margins, keep opex disciplined, ramp the Gigafactory, and convert the gross block already created into operating leverage.**

Auto Business

Service materially stabilised; strong sales recovery across states

The most important operating development of the quarter was service. It was the largest constraint on demand and brand trust through FY26. That has now materially stabilised. Average service TAT reduced by **88%**, from around **9 days in October 2025** to nearly **1 day in March 2026**. Service backlog reduced from **14 days to 6 days**. Same-day closures improved to about **87%**, and parts pendency reduced by **69%** from October to April. This came from better parts stocking, higher technician productivity, stronger repair capability, tighter daily governance and a shift from replacement-led to repair-led economics.

Gen 3 is also reducing service demand. **Warranty cost for Gen 3 is 70% lower than Gen 2**, reflecting better product quality, diagnostics and repair capability. **This improvement is also visible in our P&L: warranty cost in the current year stands at ₹59 crore, compared with ₹555 crore in FY25.**

Reduction in backlog days and uptake in registrations:

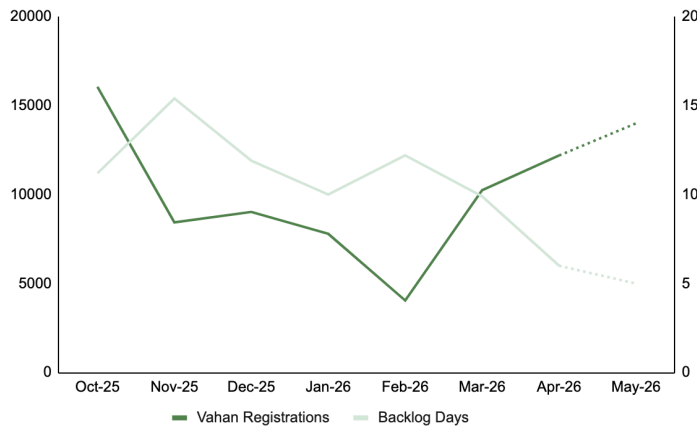

With service stabilising, sales responded strongly. April registrations rose to **12,166 units**, up **20% month-on-month**, even as the E2W industry declined by more than **22%**. The recovery is visible in weekly registrations too, showing a strengthening operating trend, not a one-month effect.

Strong improvements in weekly registrations:

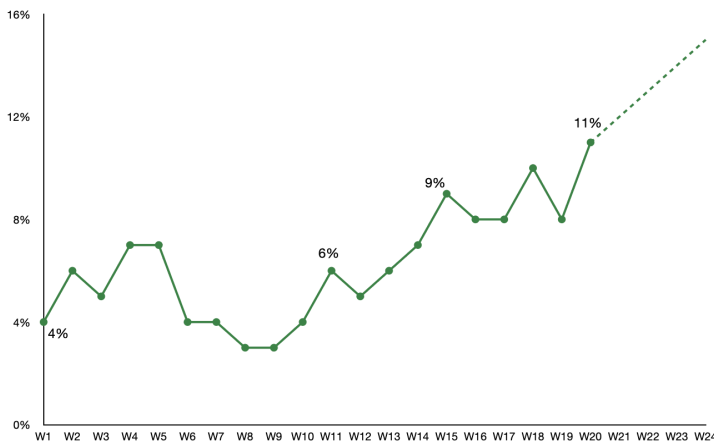

The recovery is broad-based across states. The **North** and **East** continue to **lead our sales growth**, driven by strong momentum in **U.P., Bihar, and West Bengal**, where service levels have improved significantly. The **South** and **West** have also shown **encouraging gains**, supported by service recovery in **Karnataka, Maharashtra, Tamil Nadu**, and other key markets.

Market-share across key states:

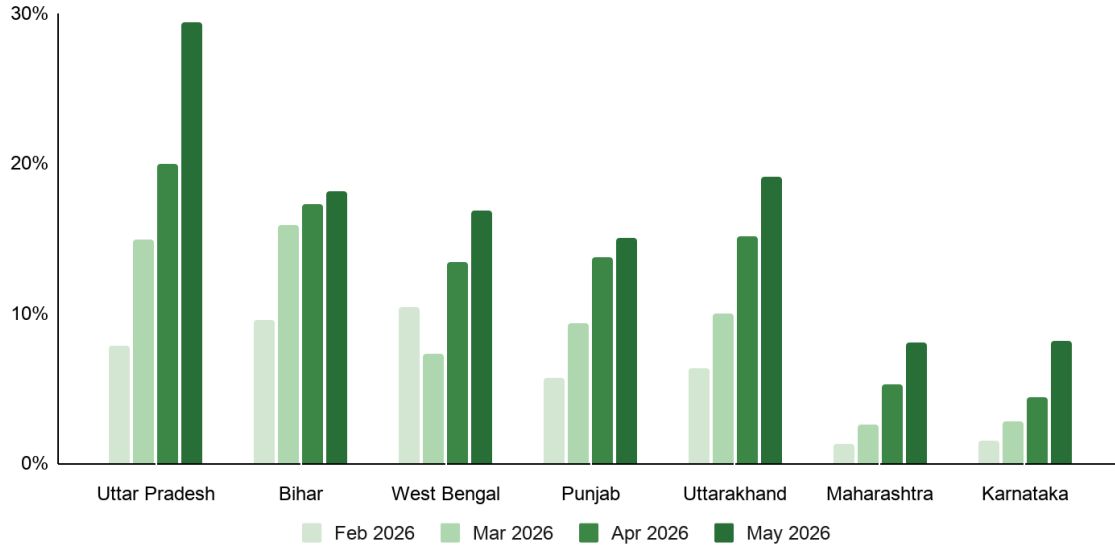

We are working towards rebuilding national market share to **15–20% over the next six months**, supported by service stability, stronger sales execution, Roadster ramp-up and better store productivity.

Roadster is becoming the second auto growth engine. The electric motorcycle market is still small, but it has grown rapidly over the last few months - **2.5x from late CY25 levels** - and Ola now has **50% market share** in the segment. Bikes contributed **15% of April gross orders**.

The customer need in motorcycles is clear: range, performance and reliability. Roadster addresses this directly, with products going up to **9.1 kWh** and **500+ km certified range**. Word of mouth on Roadster has been strong, and as production ramps, we are seeing the demand grow further. We are confident Roadster can become a meaningful growth avenue for Ola.

Demand recovery is pulling the manufacturing ramp

As sales recovered, network free inventory has reduced to only **3-4 days of sales**, and we are now running an order backlog across key products. Ramping production has therefore become a top management priority.

The focus is on supplier ramp-up, factory throughput, faster order-to-delivery conversion and rebuilding the right inventory buffers in the network. Importantly, this does not require new capex. The Futurefactory capacity is already in place — the focus now is on converting demand into deliveries.

AI is improving execution quality and cost structure

AI is becoming a core operating layer inside Ola Electric. We have built our **own in-house AI stack** which is now operating at production scale, with around **2 lakh connected calls per day** across sales, service and operations.

Our AI agents are improving execution across the business: **AI Sales agents** handle lead reactivation, multilingual engagement, test-ride scheduling and follow-ups; **service productivity AI agents** track technician and store productivity and improve closure discipline; **registration and logistics AI agents** reduce document delays, unblock movement bottlenecks and push accountability through the network. On key funnel and productivity metrics, these AI agents are already performing better than humans, while reducing cost and improving consistency.

AI is helping us build a leaner operating model: better sales conversion, faster service execution, lower operating cost and more consistent governance.

You can listen to sample Ola AI customer calls using this [link](#) or  call **+91 8044610249** for a live experience.

Brand strength and product portfolio

While service issues impacted the ownership experience for a period, the Ola brand remained strong through the reset. This strength comes from our large installed base, strong customer familiarity, and a product proposition that continues to lead on range, price and value

Ola has the largest installed base in the EV two-wheeler category, giving us a structural advantage in visibility, recall and word of mouth. Our products continue to offer among the highest range at the most competitive price points in the market.

Independent consumer research reinforces this. Among non-Ola EV users, Ola has the highest top-of-mind **EV 2W brand recall at 29%**, the **highest spontaneous brand recall at 50%**, and the highest aided brand recall at 85%. The same survey shows **Ola's overall NPS at 53, above the industry average**. More importantly, NPS rises to 64 among customers who did not face service delays, and drops to 41 among customers who faced service delays.

Top-of-Mind-Recall and Spontaneous Brand Awareness

E2W Brand Awareness among Non-Ola users (N=501)
(Taken EV 2W players)

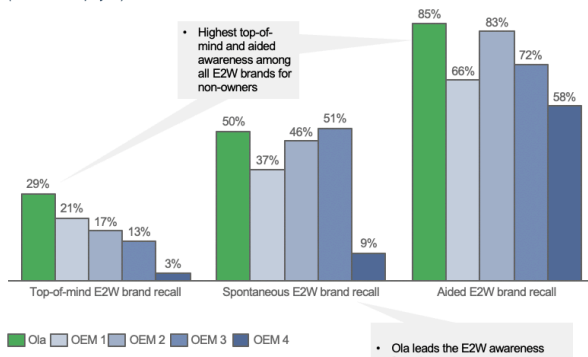

Key observations

- Ola has the **highest aided brand recall** in the overall 2W market
- Ola's **top-of-mind awareness (for E2W) is highest (~30%)**
- Ola has the **highest aided awareness** for E2W among users as well as non-users. It also has the **highest aided awareness** among those that intend to buy an E2W in the future (83%)

Net Promoter Score

NPS by Brand (N=749 Electric 2W Owners)

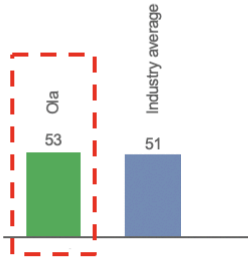

Ola NPS by Service Delay Experience

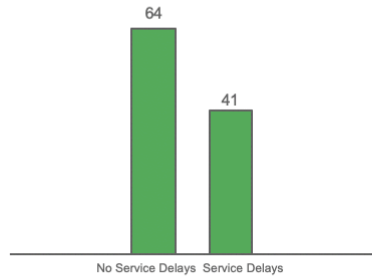

Source: Alvarez & Marsal

This is also visible in digital intent. Google Trends shows Ola significantly ahead of the category in EV search interest, reinforcing continued customer consideration.

#1 searched EV Brand in 2026:

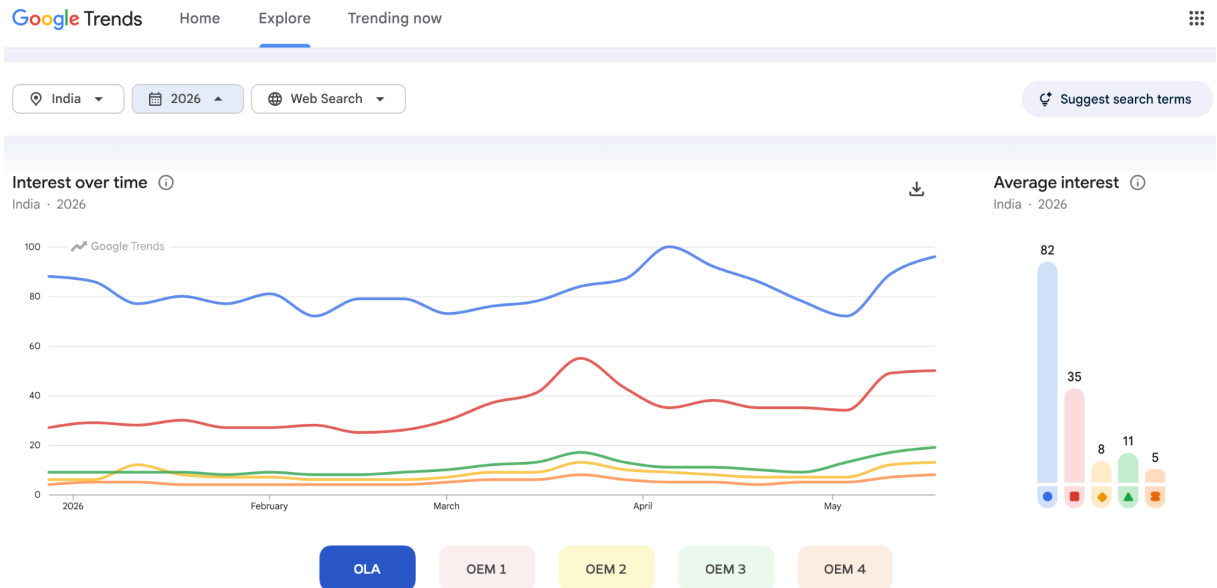

Source: Google Trends for 2026

Our portfolio now covers the largest E2W demand pools: mass scooters, premium scooters, mass motorcycles and premium motorcycles.

Products to Capitalize every segment of the market

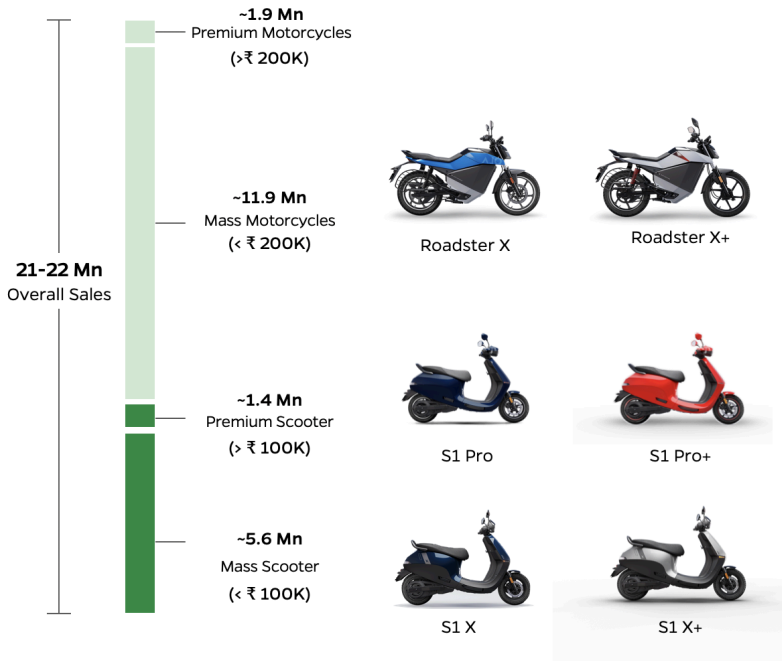

4680 integration is now strengthening the portfolio. Already, around 15% of orders are from products using our own cells, and our plan is to transition the full vehicle portfolio to own cells by September 2026. In scooters, our own-cell products increase battery capacity from 4 kWh to 5.2 kWh, **delivering 30%+ higher range**. In motorcycles, the move from 4.5 kWh to 9.1 kWh nearly doubles range, with **Roadster X+ delivering 500+ km certified range**.

Our Gen 3 platform is the foundation of this portfolio. It gives us better quality, lower warranty cost, stronger unit economics and a more capital-efficient product roadmap. Our shared platform architecture, common components and cell integration allow us to expand the portfolio without rebuilding the capex base for every product.

As operations stabilize, we will bring the next set of products to market across scooters, motorcycles and adjacent mobility products — all built on common platforms, shared R&D and the Bharat Cell roadmap.

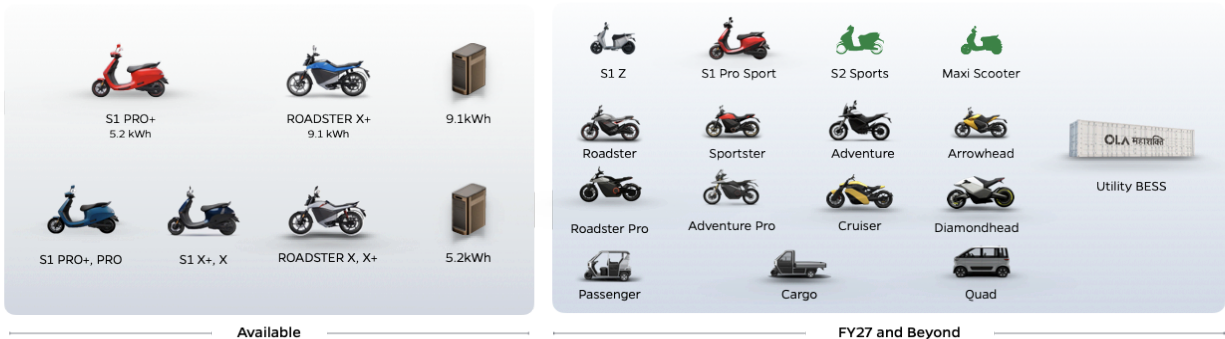

Cell Business: from validation to scale

India's battery moment is here. The next phase of India's energy security will be built not only on EV adoption, but on domestic cells and energy storage. The government's policy direction is also increasingly clear: **localise the battery supply chain**, build domestic manufacturing, support BESS deployment. As local-content rules, approved-list frameworks for **battery modules / cells, ACC PLI, BESS VGF** come into force, India's battery industry is moving from policy intent to industrial execution.

Ola is by far the best-positioned Indian company for this shift. We have already built an operating Gigafactory, in-house cell R&D, dry-electrode process know-how, vehicle integration, and now storage products. **Cells are not like solar modules**; they are technology-led and process-intensive, where chemistry, yield, safety, IP and manufacturing learning curves compound over time. This is where our early investment gives us a structural lead.

Our Cell business is now moving to manufacturing scale. Over the last few quarters, we have **commercialised 4680**, started integrating it into vehicles, **built Shakti, progressed LFP, and advanced Mahashakti product development**. The focus now is to complete the 6 GWh commercial ramp up, transition auto to own cells, scale Shakti GTM, and prepare Mahashakti for large-format storage.

India's annual battery demand (GWh):

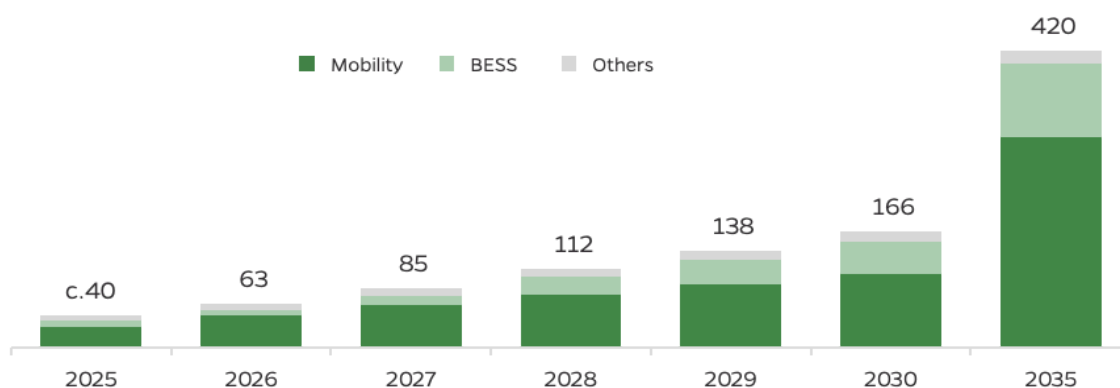

420 GWh, \$30 bn Battery opportunity by 2035, a large, visible domestic opportunity pool

Source: Avendus Research

Gigafactory: 6 GWh installation largely complete

Our Gigafactory has moved from validation to commercial scale-up. We currently have 2.5 GWh operational capacity, and the **installation to 6 GWh** is largely complete and the commercialization to be completed by the end of this quarter. We are already **operating at commercially viable yields**, which should continue improving through FY27 as throughput, process capability and line stability improve.

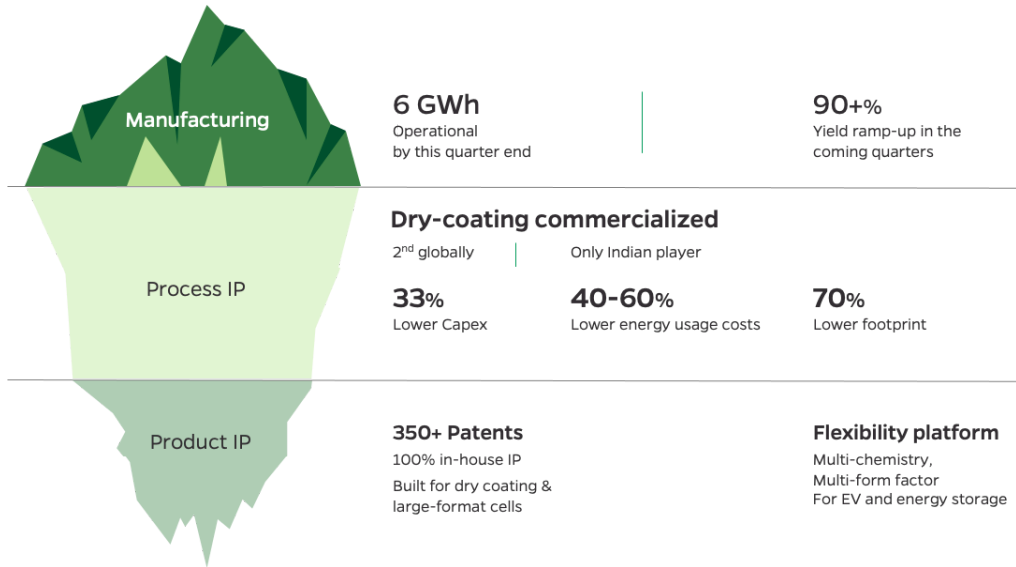

The core platform is already built. The existing Gigafactory complex gives us a path from 6 GWh to 20 GWh through incremental brownfield expansion. For now, the priority is to fully utilise the 6 GWh platform. We plan to expand to 20 GWh by early next year through capital raise at cell entity level.

Technology roadmap: NMC and LFP

NMC is the performance track. The 4680 Bharat Cell is already commercialised and deployed in our vehicles. It gives us range, power and product differentiation, especially in premium scooters and motorcycles.

LFP is the scale track. Our 46100 LFP cell has progressed meaningfully and is close to manufacturing readiness. LFP brings lower cost, longer cycle life and strong fit for affordable EVs and energy storage. In parallel, prismatic LFP is being developed for Mahashakti and large-format BESS.

This roadmap gives us flexibility across applications: NMC for performance EVs, LFP for mass EVs and distributed storage, and prismatic LFP for utility-scale BESS.

Cell technology roadmap:

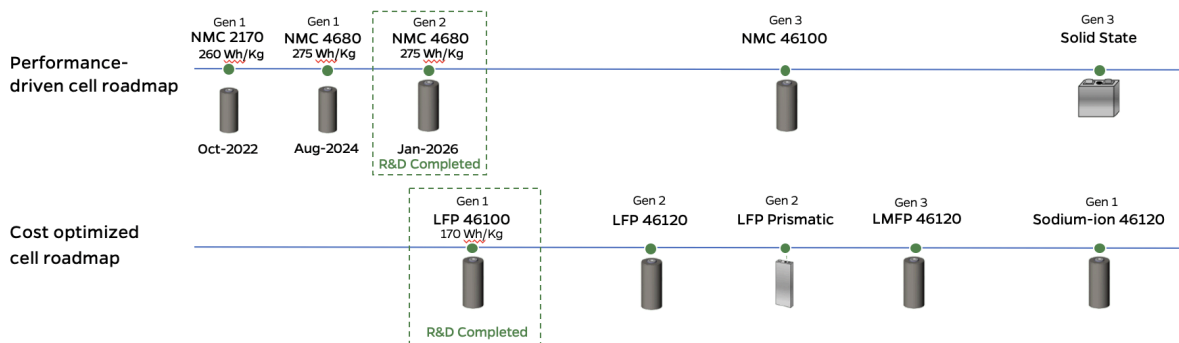

Business Model

One cell platform, three demand engines:

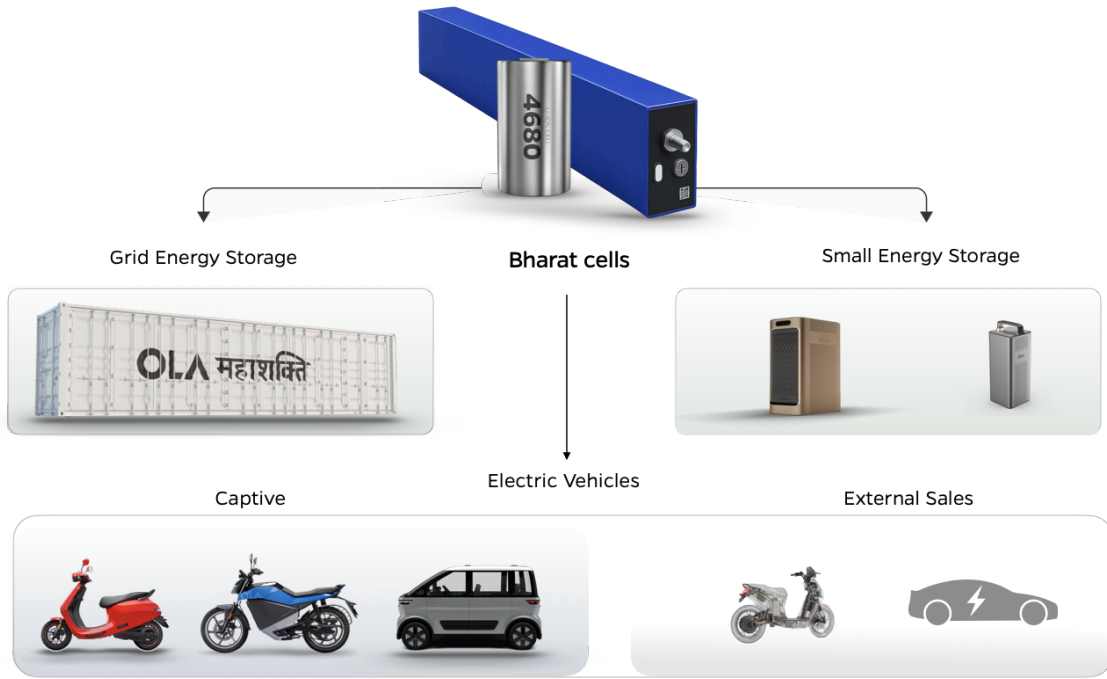

First, auto and external cell sales. Auto gives the Gigafactory captive demand from day one. This lets us ramp manufacturing at meaningful volumes from the beginning. We expect **captive cell consumption to scale to 1.5-2 GWh** by FY27 exit. We are also in discussions with external customers, including OEMs and industrial customers, who are looking for high-performance, globally-competitive cell supply.

Second, Shakti. **Shakti is now built** and entering the market. Today, we are supply-constrained as we are prioritising the auto transition while the Gigafactory ramps. The demand signal is clear, with **50k+ customer leads**, B2B discussions covering multi GWh annual scale, and strong retail interest across telecom, petrol pumps, retail, dark stores and commercial backup, supported by a **distributor/dealer-led GTM strategy with 200+ distributor partners**.



Third, Mahashakti. **Mahashakti is in product development for C&I and utility-scale storage; the product will be out by CY 2027.** We are engaging with renewable developers, utilities, EPCs, telecom clusters, data centres and grid-scale customers. This market is moving fast as renewable penetration rises and storage becomes essential for peak load, grid balancing and diesel replacement.



FY27 priorities and outlook: Scaling with discipline

In auto, the core capex is already in place. We do not expect meaningful incremental auto capex in FY27. The focus is on supplier ramp-up, factory utilisation, faster order-to-delivery conversion and rebuilding the right inventory buffers in the network.

Based on current trends, we expect Q1 FY27 orders to be **40,000 - 45,000 units**, nearly double Q4 levels. This reflects the improvement in service, sales execution, and market recovery.

As volumes recover, we expect the auto business to move towards Adjusted Operating EBITDA and free cash flow positivity through FY27. This will be driven by our **high gross margins**, further opex reduction over the next couple of quarters, working-capital discipline, supplier and factory ramp-up, and better utilisation of the gross block already created.

Q1 and Q2 margins may moderate from Q4 levels due to commodity inflation and pricing investments to accelerate growth. However, **our vertical integration, margin leadership and own-cell roadmap** give us the buffer to remain aggressive on customer value while continuing to lead the industry on unit economics.

In Cell, the tail-end capex for the 6 GWh ramp will come through Q1 and Q2. Beyond 6 GWh, our plan is to expand towards 20 GWh through capital raised at the Cell entity level. This keeps the Cell growth plan focused, while allowing us to build leadership in a market where scale, technology and timing matter.

Our FY27 priorities are clear: recover volumes, sustain service consistency, hold margin leadership, reduce opex, ramp the Gigafactory, and scale Shakti and Mahashakti.

Key Financial Metrics

Key Operating Metrics	Q4 FY25	Q1 FY26	Q2 FY26	Q3 FY26	Q4 FY26	FY25	FY26
Orders (units)					22,522		
Registrations (units)					22,088		
Deliveries (units)					20,256	307,846	173,794
Consolidated (in ₹cr)	Q4 FY25	Q1 FY26	Q2 FY26	Q3 FY26	Q4 FY26	FY25	FY26
Revenue from Operations	611	828	690	470	265	4,514	2,253
Gross Margin	84	214	213	161	102	806	690
Gross Margin (%)	13.7%	25.8%	30.9%	34.3%	38.5%	17.9%	30.6%
Operating Expenses	779	451	416	432	383	2545	1,682
Adj. Operating EBITDA	-760	-296	-258	-323	-326	-1,903	-1,203
Adj. Operating EBITDA Margin (%)*	-124.4%	-35.7%	-37.4%	-68.7%	-123.0%	-42.2%	-53.4%
PAT	-870	-428	-418	-487	-500	-2,253	-1,833
CFO	-291	-143	-200	-523	91	-2391	-775
FCF	-625	-282	-350	-729	-131	-3367	-1,492
Automotive Segment (in ₹cr)	Q4 FY25	Q1 FY26	Q2 FY26	Q3 FY26	Q4 FY26	FY25	FY26
Revenue from Operations	611	826	688	467	264	4,514	2,245
Gross Margin	84	212	211	158	101	806	682
Gross Margin (%)	13.8%	25.6%	30.7%	33.8%	38.3%	17.9%	30.4%
Operating Expenses	638	308	258	273	270	2066	1,109
Adj. Operating EBITDA	-612	-155	-102	-167	-213	-1,174	-637
Adj. Operating EBITDA Margin (%)*	-100.2%	-18.8%	-14.8%	-35.8%	-80.7%	-26.0%	-28.4%
PAT	-705	-261	-233	-289	-341	-1,686	-1,124
CFO	-246	-86	-95	-444	213	-2042	-412
FCF	-520	-166	-163	-505	173	-2,597	-661
Cell Segment (in ₹cr)	Q4 FY25	Q1 FY26	Q2 FY26	Q3 FY26	Q4 FY26	FY25	FY26
Revenue from Operations	4	3	4	9	4	12	20
Gross Margin	3	2	2	4	-3	7	4
Gross Margin (%)	79.3%	65.2%	50.0%	42.3%	-75.0%	55.6%	20.4%
Operating Expenses	32	45	52	51	33	106	181
Adj. Operating EBITDA	-36	-44	-51	-53	-42	-127	-191
Adj. Operating EBITDA Margin (%)	-120.1%	-164.3%	-189.9%	-228.5%	-527.9%	-1059.2%	-974.5%
PAT	-53	-69	-79	-89	-82	-191	-319
CFO	-16	-32	-62	-46	-39	-89	-179
FCF	-76	-91	-143	-192	-221	-510	-647

*Adj. Operating EBITDA refers to Operating EBITDA (excluding other income) including the lease expenses.

Key Graphs

All numbers in ₹ Cr unless otherwise stated

Graph 1: Industry E2W volumes and EV Penetration

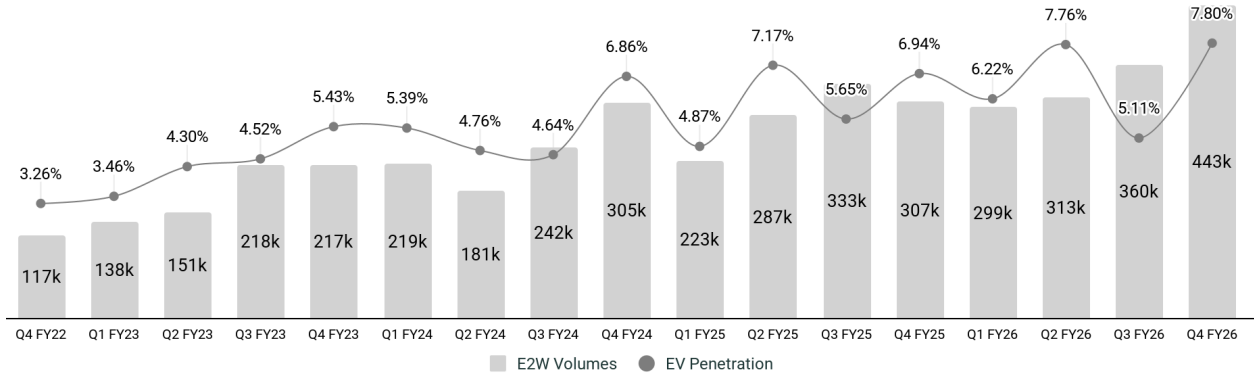

Graph 2: Average Selling Price (ASP) per unit in ₹

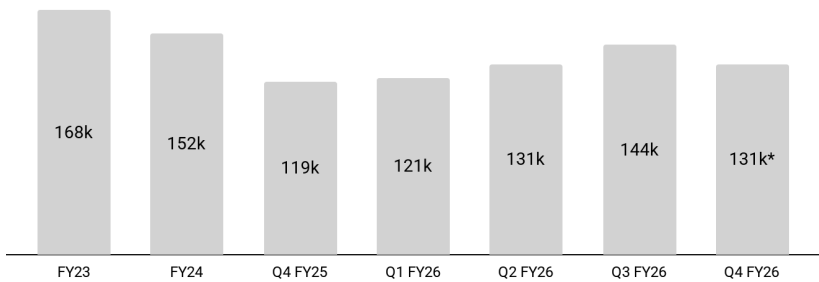

* one-time change in revenue recognition policy

Graph 3: Consolidated GM per unit in ₹

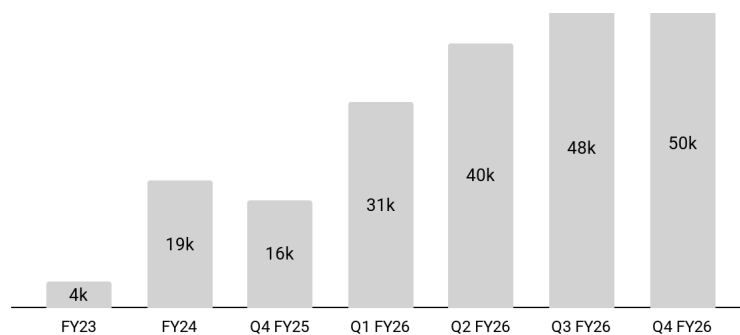

Graph 4: Consolidated Gross Margin and Gross Margin excluding PLI

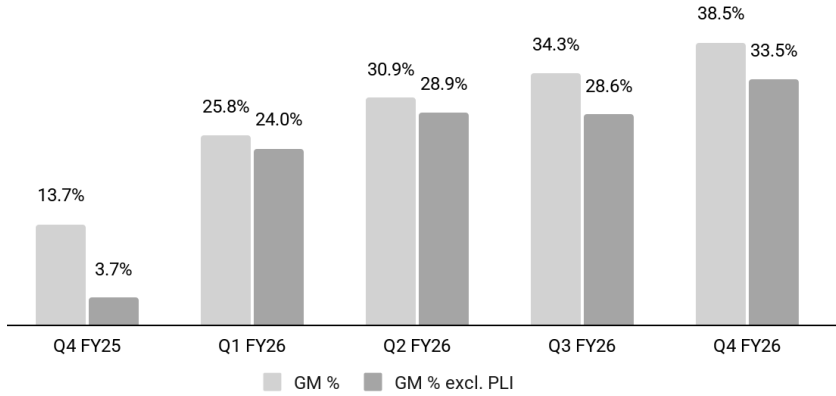

Graph 5: Consolidated Adjusted Operating EBITDA & Adjusted Operating EBITDA Margin* for Q4 FY 26:

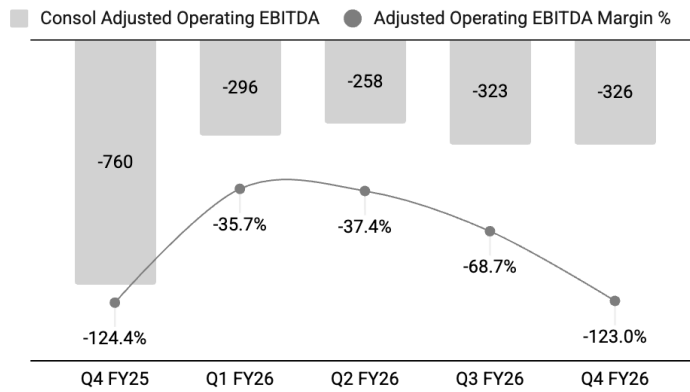

* Consolidated Adjusted Operating EBITDA represents consolidated operating EBITDA (viz. Excluding other income) adjusted for lease expenses.

Graph 6: Consolidated Adjusted Operating EBITDA to CFO to FCF walk

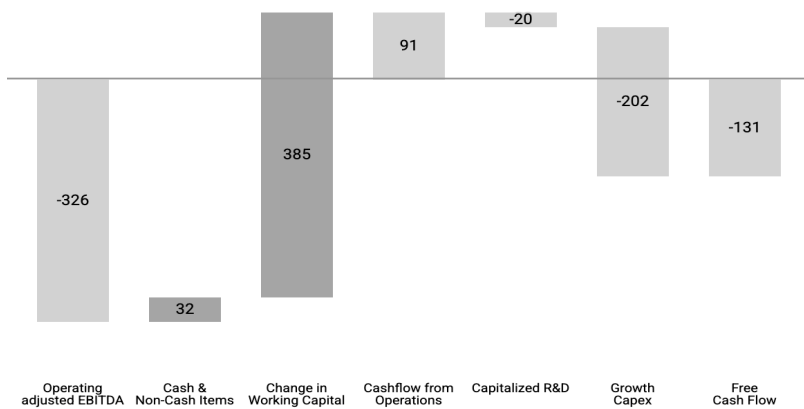

* Consolidated Adj. Operating EBITDA Margin refers to Operating EBITDA (excluding other income) including the lease expenses

Graph 7: Segment to Consolidated CFO walk

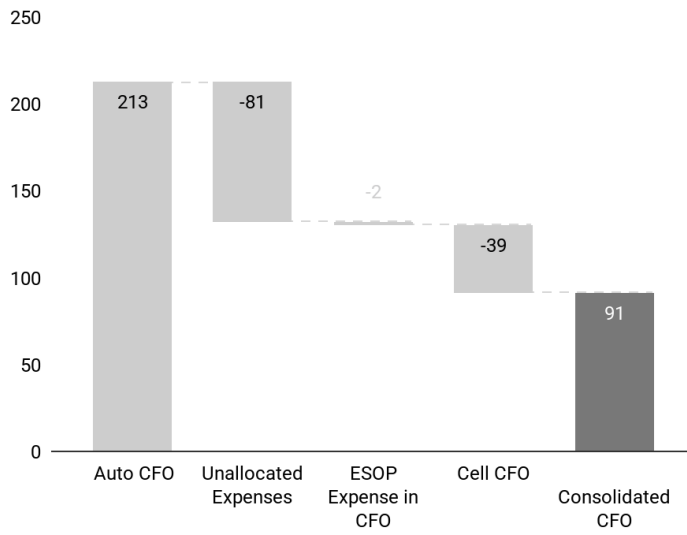

Graph 8: Auto FCF to consolidated FCF walk

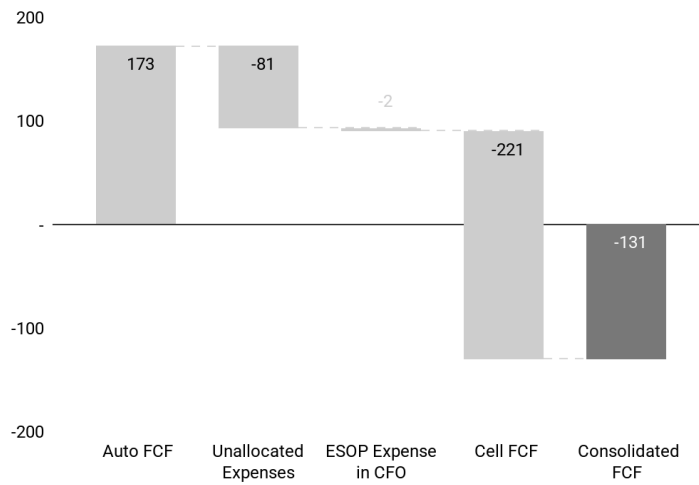

Photographs | Q4 FY26 Highlights

First Shakti Roll-out | Jan 2026



Videos | Q4 FY26 Highlights

EndICEAge Campaign



Scan QR code or [click here](#) to play this video

Ola S1 X+ Made with 4680 cell

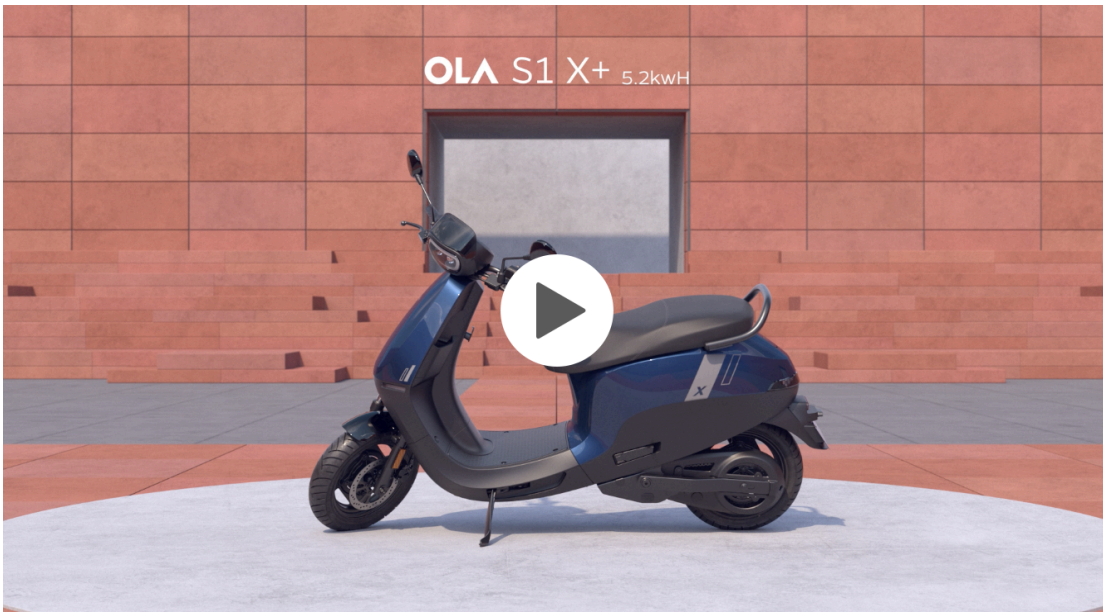

Scan QR code or [click here](#) to play this video



MANIFESTO

If you're going to dream,
make it an impossible one.
And then, make it happen.

If you're travelling new paths,
be up for doing it alone.

If you're proud of where you are from,
make where you're from proud of you.

If you're going to compete,
start where everybody else finishes.

If you're looking for a reaction,
don't settle for anything less than-"woah!".

If you're going to start something,
start something new.
The world does not need another thing
just like the other thing.

And if you're looking for the future,
stop looking. Make it.

Disclaimer

This document, except for historical information, may contain certain forward-looking statements including those describing the Company's strategies, strategic direction, objectives, future prospects, estimates etc. Forward-looking statements can be identified generally as those containing words such as 'expects, anticipates, intends, will, would, undertakes, aims, estimates, contemplates, seeks to, objective, goal, projects, should' and similar expressions or variations of these expressions or negatives of these terms. These forward-looking statements are based on certain expectations, assumptions, anticipated developments and are affected by factors including but not limited to, risk and uncertainties regarding any changes in the laws, rules and regulations relating to any aspects of the Company's business operations, general economic, market and business conditions, new or changed priorities of trade, significant changes in political stability in India and globally, government regulations and taxation, litigation, competition among others over which the Company does not have any direct control. The Company cannot, therefore, guarantee that the forward-looking statements made herein shall be realized. The Company undertakes no obligation to publicly update or revise any forward-looking statements, whether as a result of new information, future events, or otherwise. In addition to Financial information presented in accordance with Ind AS, we believe certain Non-GAAP measures are useful in evaluating our operating performance. We use these Non-GAAP financial information to evaluate our ongoing operations and for internal planning and forecasting purposes. We believe that Non-GAAP financial information, when taken collectively with financial measures prepared in accordance with Ind AS, provides an additional tool for investors to use in assessment of our ongoing operating results and trends because it provides consistency and comparability with past financial performance.